

Dirsek	Derece	çap(ϕ)	Miktar
D1	90°	650mm	1 Adet
D2	90°	650mm	1 Adet
D3	63°	150mm	7 Adet
D4	90°	150mm	1 Adet
D5	90°	190mm	8 Adet
D6	90°	150mm	3 Adet
D7	27°	100mm	3 Adet
D8	90°	100mm	2 Adet

B.no	boru çapı(Q)	uzunluk(L)(m)
B1	650mm	2,65m
B2	650mm	10.3m
B3	650mm	2,00m
B4	610mm	2,2m
B5	560mm	4,2m
B6	515mm	3,00m
B7	460mm	5,00m
B8	400mm	3,00m
B9	330mm	7,80m
B10	230mm	3,15m
S1	150mm	48m
S2	150mm	40m
S2-1	100mm	80m

Çizen		Tarih	Ad Soyad	İmza	Onay	
Mak.Et.P.Şb.Md.			Selami COŞKUN		 Selahattin EYÜBOĞLU Makina Daire Başkanı V.	
Makina Şb.Müd.			Orhan YAVUZ			
			Selahattin EYÜBOĞLU			
Ölçek	1:20	Parça Adı :			Malzeme	Resim No
Ağırlık		ÇAY PAKETLEME FABRİKASI TOZ TOPLAMA BORU ve DİRSEK İMALATI KESFİ				PT-2018-7
İmalat Adeti					Ürün Kodu	

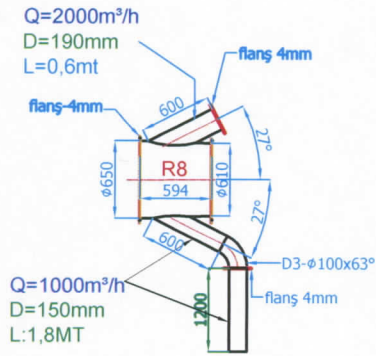

İMALAT:1ADET

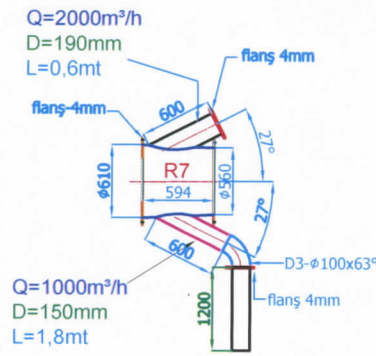

İMALAT:1ADET

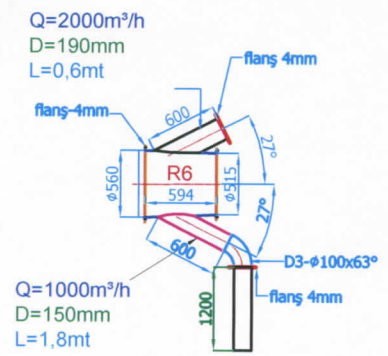

İMALAT:1ADET

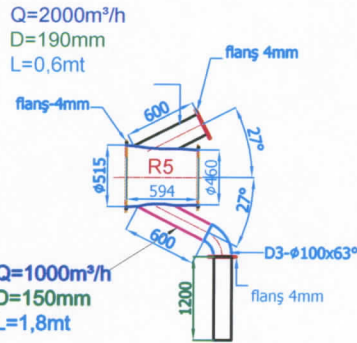

İMALAT:1ADET

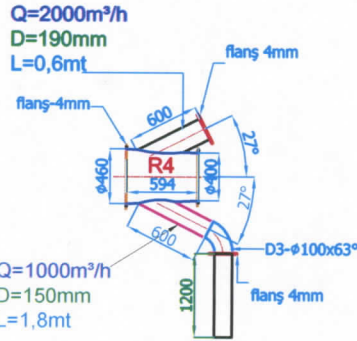

İMALAT:1ADET

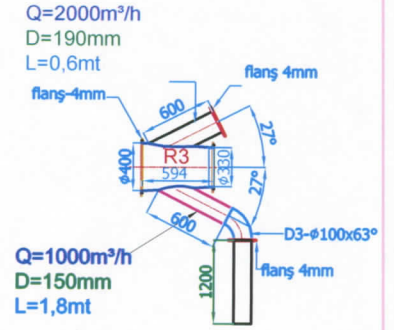

İMALAT:1ADET

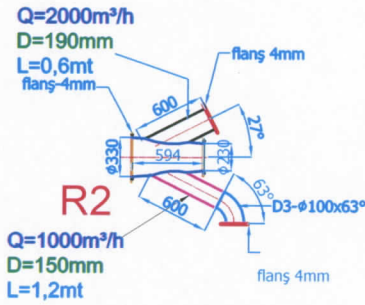

İMALAT:1ADET

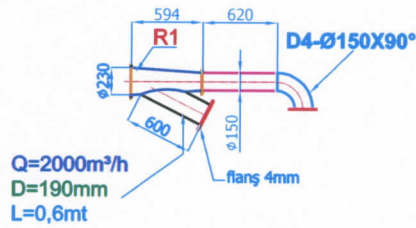

İMALAT:1ADET

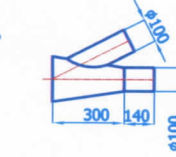

R10-
İMALAT:8ADET

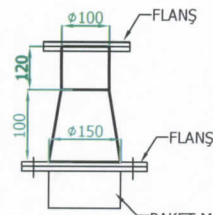
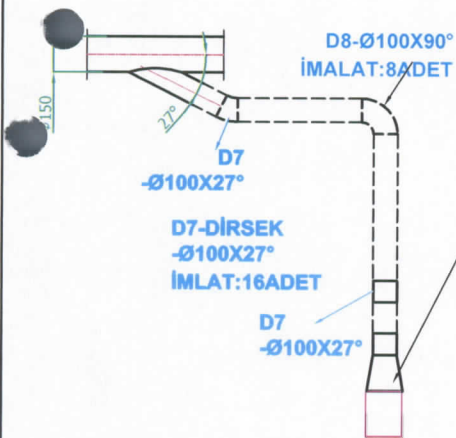

S2 PAKET MAKİNASI ÇIKIŞI VAKUM BAĞLANTI BORUSU ARA PARÇASI
İMALAT:8ADET-

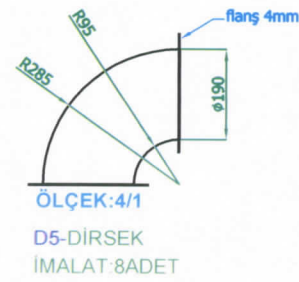

	Tarih	isim	imza
Çizen		Selami COŞKUN	
Mak.Et.Prj.md.		Orhan YAVUZ	
Makina Müd.		Selahattin EYÜBOĞLU	
ÖLÇEK			
		ÇAY PAKETLEME FABRİKASI TOZ TOPLAMA İMALATLARI PROJELERİ	
			Resim no PT-2018-6

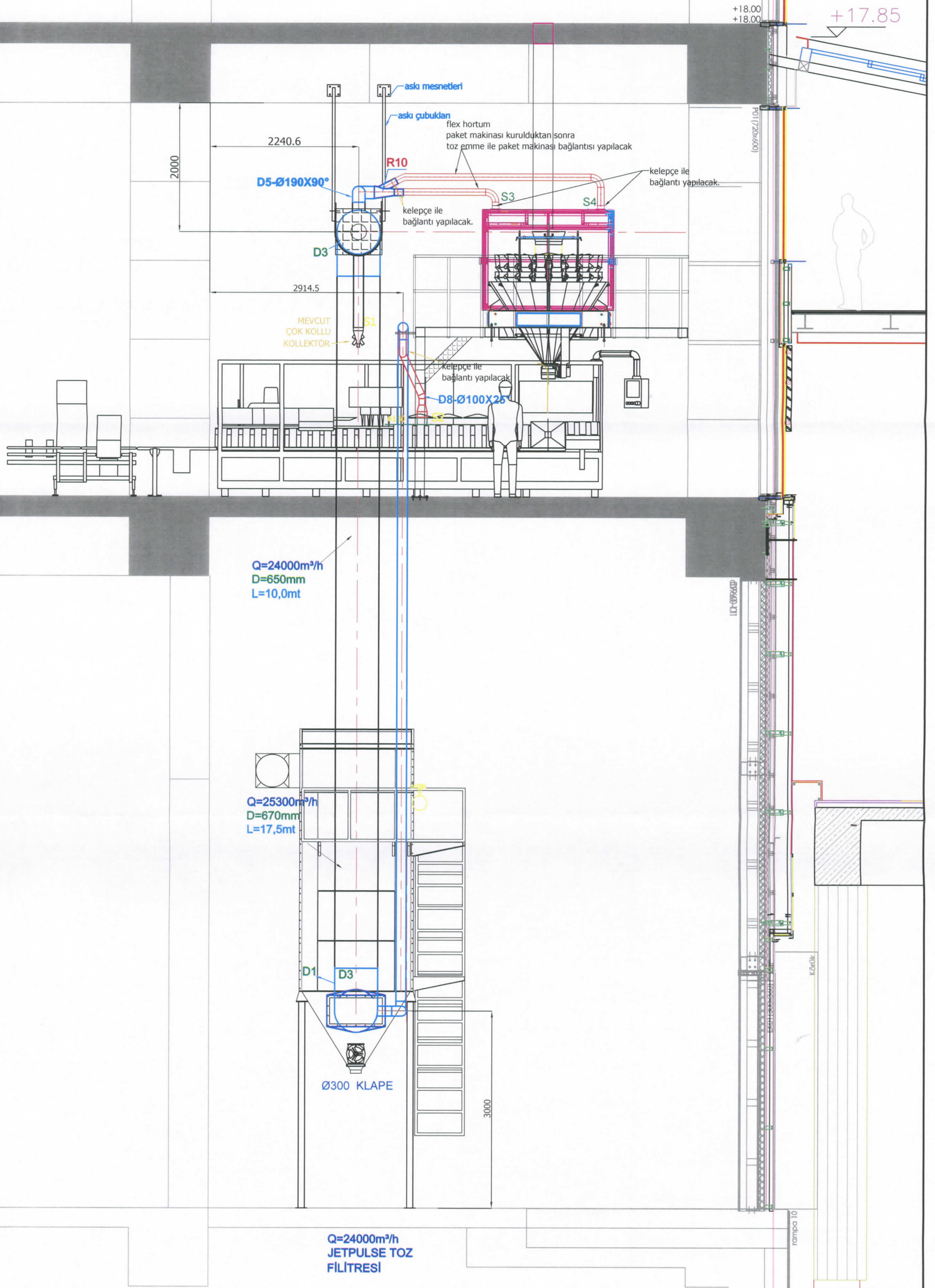

B-B KESİTİ

	Tarih	isim	imza	
Çizen		Selami COŞKUN		Selahattin EYÜBOĞLU Makina Dairesi Başkanı V.
Mak.Et.Prj.md.		Orhan YAVUZ		
Makina Müd.		Selahattin EYÜBOĞLU		
Mlz.Pl.n.Müd.				
ÖLÇEK	ÇAYKUR PAKETLEME FABRİKASI JETPULSE FİLTRE VE VANTİLATÖR YERLEŞİMİ KESİT (B-B) TOZ EMME PROJESİ			Resim no
				PT-2018-4

doğru

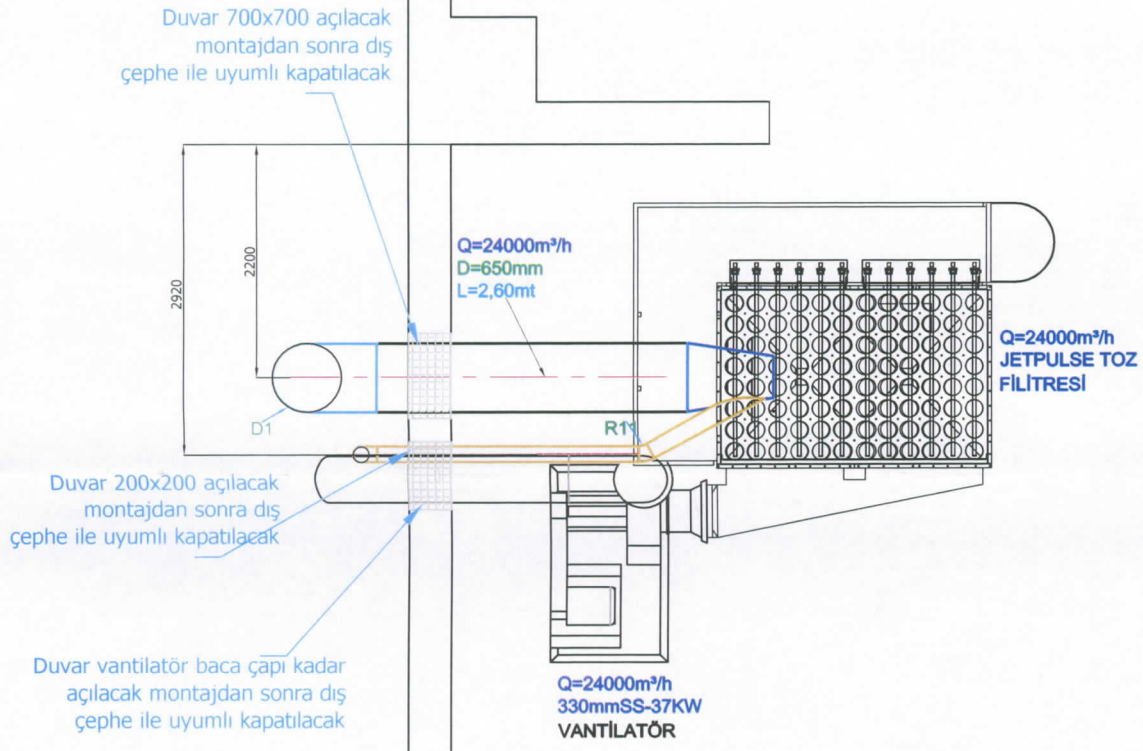

not:Peket makineleri toz toplama sistemine ait jetpulse toz filtreli sistem ve vantilatör gurubu yerleşimi gösterilen mahale proje yerleşimi yapıp ilgili daireden okey alındıktan sonra imalat ve montaj yapılacaktır.vantilatör bacası sistem dışına duvar delinerek baca aşağı bakacak şekilde projelendirilecektir.

kuzey

	Tarih	isim	imza	
Çizen		Selami COŞKUN		 Selahattin EYÜBOĞLU Makina Dairesi Başkanı V.
Mak.Et.Prj.md.		Orhan YAVUZ		
Makina Müd.		Selahattin EYÜBOĞLU		
ÖLÇEK		ÇAYKUR PAKETLEME FABRİKASI JETPULSE FİLTRE VE VANTİLATÖR YERİ FSİMİ TOZ FMMF PRO.FSİ-7FMİN KAT		Resim no P-2018-3